

# Integrated Helm Control Installation for BOLT Electric Systems



2.25"  
Depth

## PN: OBI9000E

For information on a complete BOLT Electric Trim Tab System, please visit [BennettTrimTabs.com/BOLT](http://BennettTrimTabs.com/BOLT)

## Installation Instructions

### ✓ Items Included

- Integrated Helm Control including lock nut

### ⚙ Tools Required

- Power drill
- 2.5" Hole saw bit

- Before drilling any holes, read the entire instructions.
- Using the included drilling template, mark the location of the 2.5" center hole.
- Check carefully to ensure there are no obstructions behind the console before drilling.
- Using a 2.5" diameter hole saw, drill the center hole.
- Place the helm control into the console, feeding the cables through the 2.5" center hole.
- Once the helm control is properly seated, tighten the large lock nut hand tight (do not over-tighten).
- Plug the helm control cable marked with the red band to the port black and white twisted extension cable from the port actuator. Note: Some systems may use a blue and yellow twisted extension cable.
- Plug the helm control cable marked with the green band to the starboard black and white twisted extension cable from the starboard actuator. Note: Some systems may use a blue and yellow twisted extension cable.
- Connect the thicker orange (or red) wire from the helm control to (+) 12V (20A) power, and the black wire to ground. The power circuit must be protected with a 20A circuit breaker or fuse.
- Connect the purple wire from the helm control to the ignition to enable ATR (Auto Tab Retraction). *When the ignition is powered off, the trim tabs will automatically retract.*
- Connect the thin orange wire to helm power. This will turn the unit on and off.

**Please note:** Although the tabs will auto-retract when the ignition is powered off, it is normal for the 4 corner LEDs to remain lit, and for the system to remain functional until battery power has been disabled.

**Troubleshooting** Information can be found at [BennettTrimTabs.com/OBI-Troubleshoot](http://BennettTrimTabs.com/OBI-Troubleshoot)

**Have questions?** We're here to help.

Visit [BennettTrimTabs.com](http://BennettTrimTabs.com) or call (866)894-1626.

## Wiring Diagram

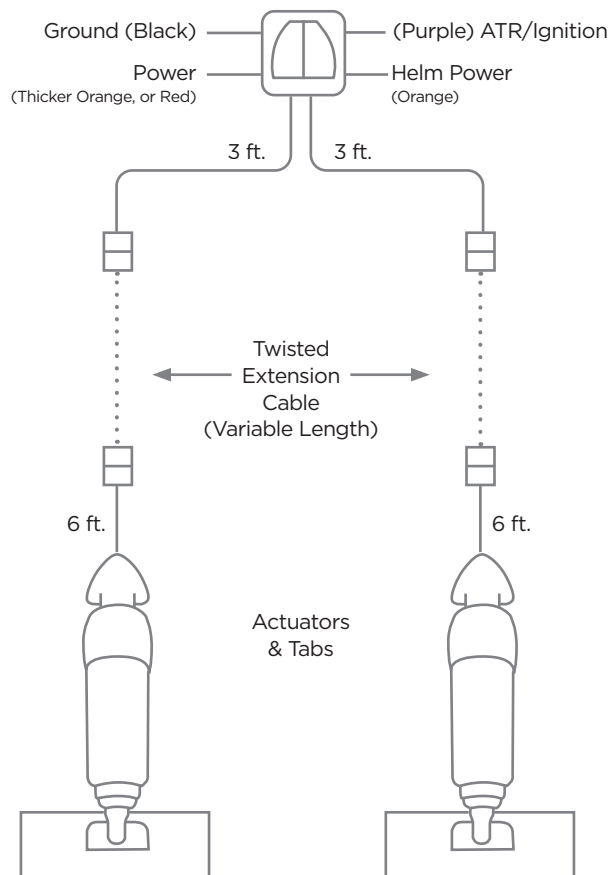

## Drilling Template

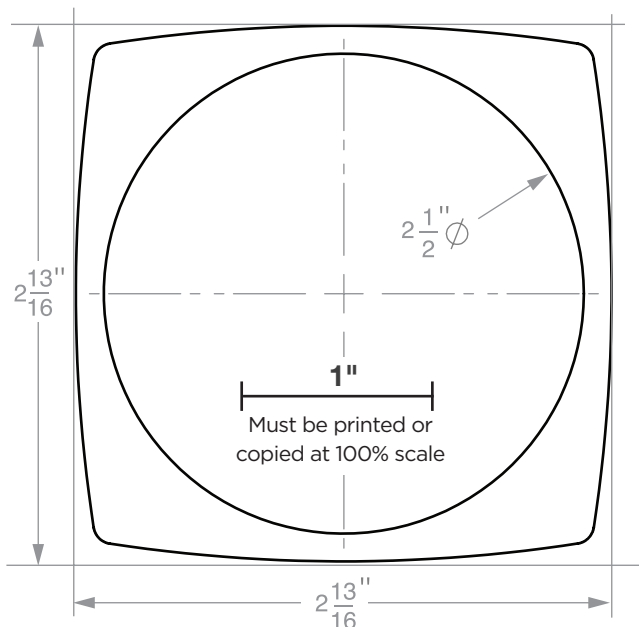

Properly sized trim tabs improve the performance of your boat by adjusting the running angle of your vessel. Bennett Marine trim tabs help you get on plane faster, correct listing, improve visibility, and increase your fuel efficiency and performance.

- Get up on plane quickly, and at lower speeds
- Increase performance and fuel efficiency
- Increase visibility and safety
- Adjust the boat's running attitude for changes in speed, sea conditions, and shifting weight
- Correct listing and porpoising

## How Trim Tabs Work

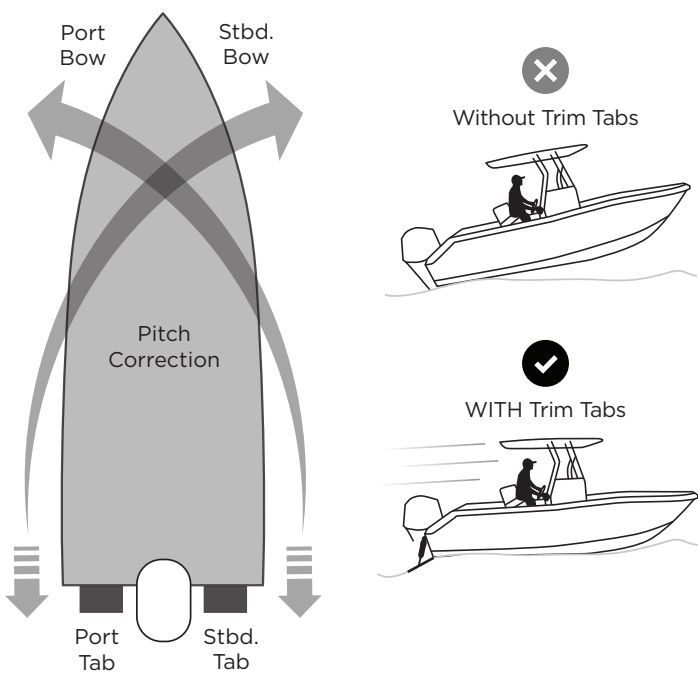

When the tabs are deployed downward, the water force on the trim tab surface creates upward pressure, raising the stern and lowering the bow. The port trim tab lowers the starboard side bow, and the starboard trim tab lowers the port side bow.

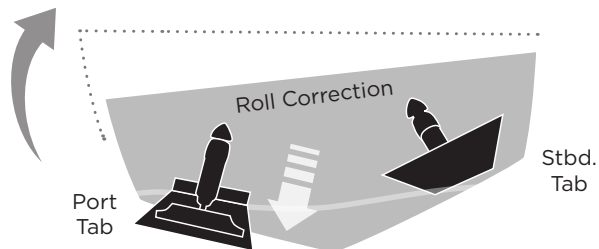

When the port tab is lowered independently, an upward force at the port stern of the boat is created. The inverse applies when lowering the starboard tab independently.

## Operating the Helm Control

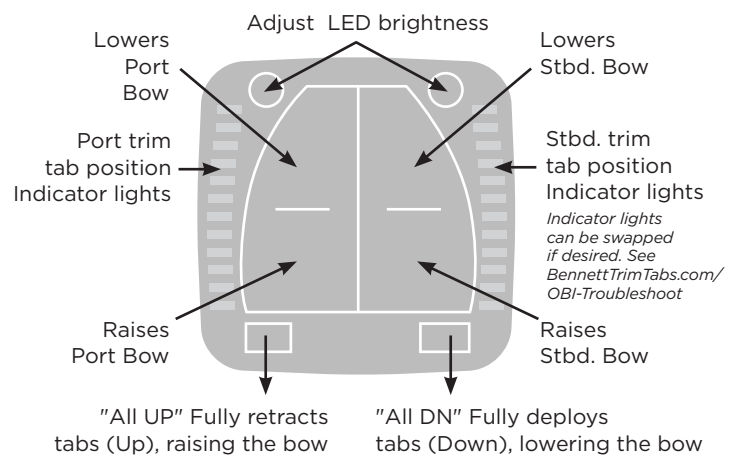

Trim tabs are easy to use. After just a few times using, tab operation will become second nature. The concept is simple but the results are impressive.

### Making Small Adjustments

The key to getting the best results from your trim tabs is to operate them in short half-second "bursts" and let the boat react before making another adjustment. The amount of time between corrections is influenced by the size of the trim tabs and the boat's speed.

### ALL Up, All Down Buttons

Enjoy the ability to fully retract or deploy your trim tabs with a single touch. The "All UP" and "All DN" buttons may have a dramatic effect on the running attitude of the boat, especially at high speeds. Please use with caution.

## Learn More About Trim Tabs



Learn more about trim tabs at [BennettTrimTabs.com/Guide](https://BennettTrimTabs.com/Guide)

- Key features & benefits
- System comparison
- Sizing guidelines
- Install tips, and more

**Have questions?** We're here to help.

Visit [BennettTrimTabs.com](https://BennettTrimTabs.com) or call (866)894-1626.