



## NMEA1 INSTALLATION INSTRUCTIONS

### READ INSTRUCTIONS COMPLETELY BEFORE BEGINNING INSTALLATION

- IF ACTUATOR STROKE IS LESS THAN 1" OR MORE THAN 2-1/2", OR IF LESS THAN 1" OF PISTON SHAFT IS EXPOSED WHEN THE ACTUATOR IS FULLY RETRACTED, HAS EXTERNAL HYDRAULIC CONNECTION, OR THREE RINGS MOLDED ON CYLINDER BODY (SEE FIGURE 1), SPECIAL SENSOR COILS ARE REQUIRED. (CONTACT BENNETT MARINE)
- MAKE ALL ELECTRICAL CONNECTIONS WITH POWER OFF
- **TEST SYSTEM BEFORE PUTTING THE BOAT BACK IN THE WATER**

#### Tools required:

- |                     |                |                      |
|---------------------|----------------|----------------------|
| 1/2" & 7/16" Wrench | Teflon Tape    | Marine Grade Sealant |
| 5/16" Drill Bit     | Wire Stripper  | Vise Grips           |
|                     | Electric Drill | Wire Cutter          |

#### Installing New Upper Hinge with Sensor

**Step 1** Inside transom, with tabs in full up position, locate trim tab hydraulic line and detach tubing from brass elbow (some fluid will drip out). While holding pipe nipples with vise grips, unscrew brass elbow. Do this procedure for port and starboard cylinders (see figure 2). If there is no pipe nipple visible inside the transom, you have a short fitting connection (see figure 3), skip to step 2.

**Step 2** Outside transom, snap white plastic clip on shaft protruding from bottom of cylinder. Grasp cylinder body with both hands and unscrew counterclockwise from cylinder upper hinge (a small amount of fluid will spill).

**Step 3** Insert metal rod into piston, POINTED END DOWN. Make sure that the O-ring is in place in new upper hinge with sensor coil. Screw new upper hinge onto cylinder while keeping metal rod inserted into center of sensor coil. Red cable for port side and green cable for starboard side. Tighten upper hinge hand tight. **IMPORTANT:** Use care when handling sensor coils during assembly to avoid damaging wires.

**Step 4** Remove upper hinge from transom and remove pipe nipple. If you have a short fitting use a 7/16" wrench to remove it from the upper hinge.

**Step 5** Remove plastic clip from piston and repeat steps 2 - 4 for the starboard cylinder.

**Step 6** Using template, drill 5/16" hole in transom for the sensor cable. Screw pipe nipple into new actuator upper hinge. Tighten nipple hand tight. Then, with vise grips, tighten two full turns . . . **NO MORE.** If you have the short fitting, using a 1/2" wrench screw it in until the fitting is snug, the shoulder of the fitting will just touch the plastic of the upper hinge.

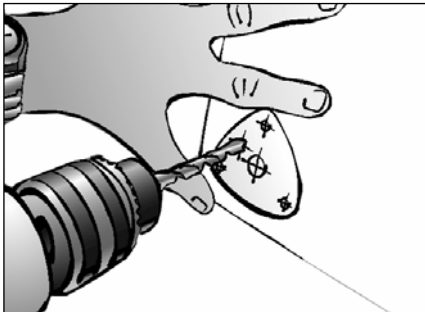

**Step 7** Cover end of pipe nipple with masking tape. Apply sealant to actuator upper hinge surface around pipe nipple, screw holes, and cable. Feed actuator cable through 5/16" hole and secure actuator upper hinge to transom with mounting screws. Grasp cylinder body with both hands and tighten (clockwise) securely. Repeat for other side. Run cables to helm.

**Step 8** Inside transom, remove masking tape from pipe nipples. Carefully wrap Teflon tape around male threads of pipe nipples. Holding pipe nipples with vise grips (to prevent them from turning) re-secure 90 degree elbows. Re-attach hydraulic tubing, tightening nut finger tight. Snug nut with 1/2" wrench. **Do not over-tighten.** Note: If you have the short fittings omit this step.

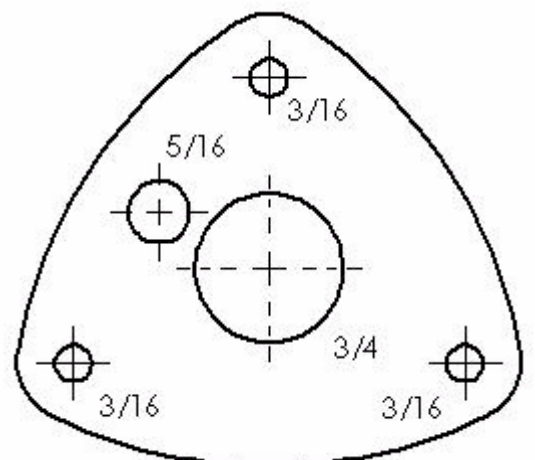
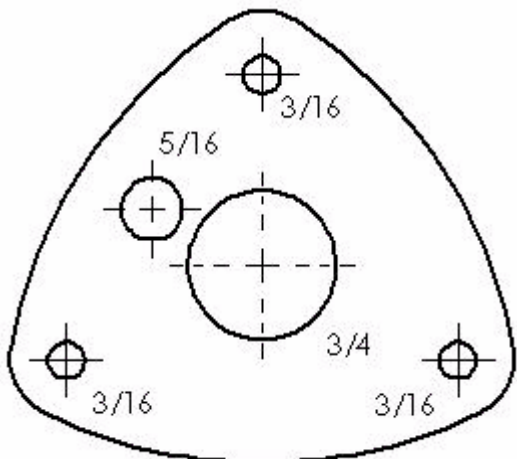
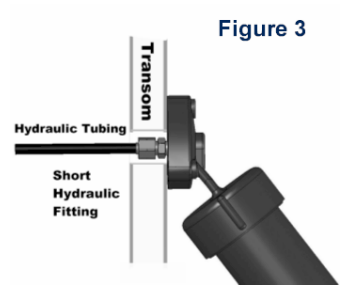
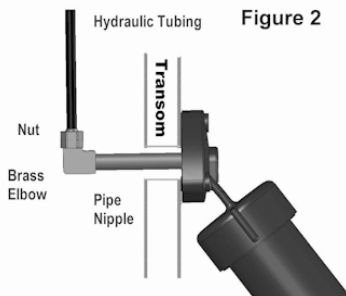
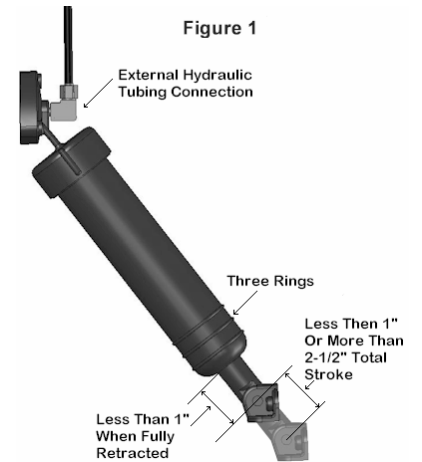

## Wiring NMEA1 to NMEA2000 Backbone

1. Using red butt connectors, splice the red and green wires from sensors to the red and green wires from the NMEA1 module. Note either red and green wires from the sensor may be spliced to either red or green wire from the NMEA1 module.
2. Run the connection cable from the NMEA1 Module to the Backbone cable of your NMEA2000 system.
3. Connect the cable into the Backbone using a red Device Net "T" (not included). You will need to purchase this "T" or buy an adapter to fit your current NMEA2000 system. Please contact your electronics manufacturer.
4. Make sure the Backbone system has the correct terminator in place.
5. Your NMEA1 Trim Tab position sensor is now installed. Refer to the Lowrance, or other electronics manufacturer's instructions for calibration of the system.

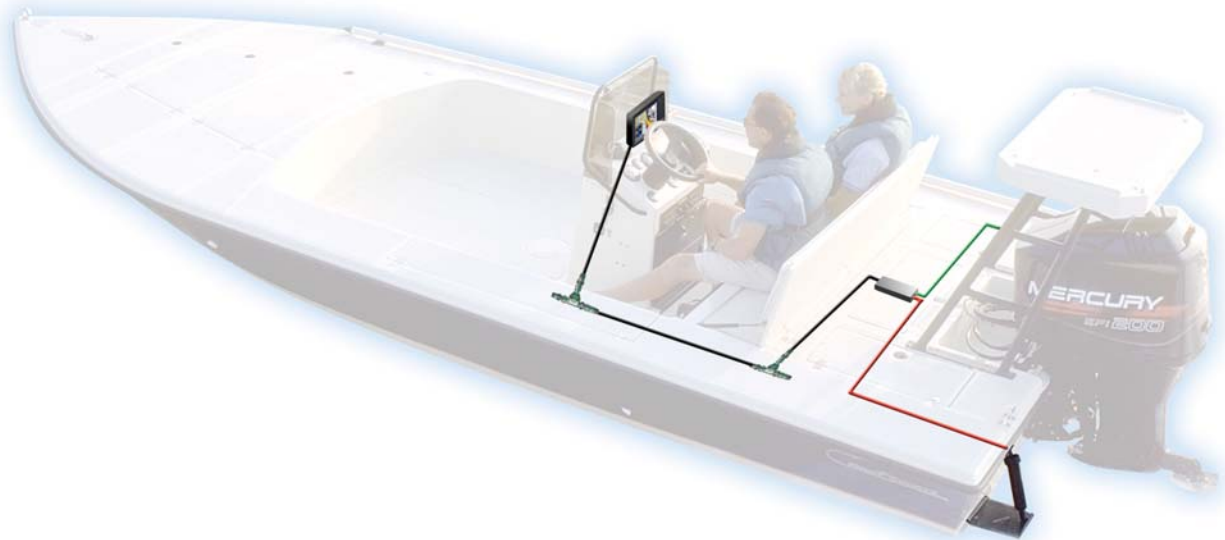
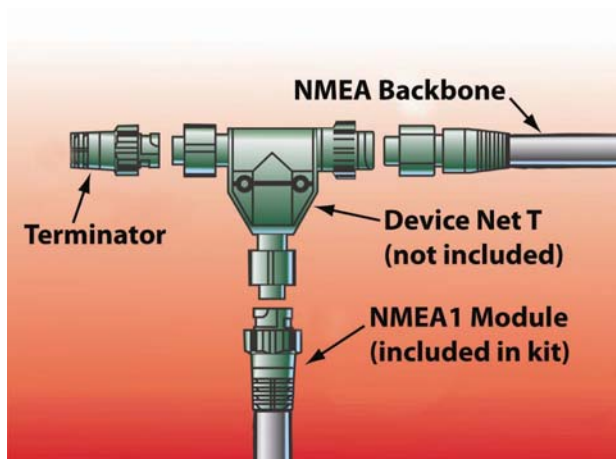
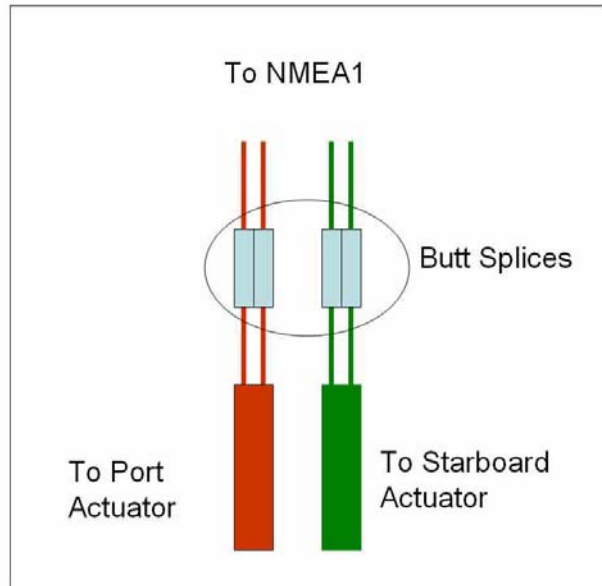

For product support, please call **1-866-894-1626 (Option #3)**, or email **BMI\_Info@Yamaha-motor.com**.  
Bennett Marine is a Division of Yamaha Marine Systems Company, Inc. - Learn more at **BennettTrimTabs.com**