



Replacing a Hydraulic Actuator Upper Hinge

Please note Thwires, do not drill the sensor hole.

Before Installation

Before drilling any holes, read the entire instructions, and make sure the battery power is disconnected.

Required Tools and materials

- 7/16" & 1/2" Wrench
- Teflon tape
- 3M 5200 or similar marine grade sealant
- 5/16" Drill bit
- Electric drill
- Vise grips

Installation Instructions

Step 1 - Inside the transom, with tabs in full up position, locate the trim tab hydraulic line. If there is no pipe nipple visible inside the transom, you have a "Short through" transom fitting connection, (Figure 2). Unscrew and remove the actuator away from the transom and use a 7/16" wrench to remove the tubing from the upper hinge. Skip to step 3.

For standard installations, detach tubing from the brass elbow (some fluid will drip out). While holding the pipe nipple with vise grips, unscrew the brass elbow using a 9/16" wrench. Repeat this procedure for both the port and starboard cylinders (see Figure 3).

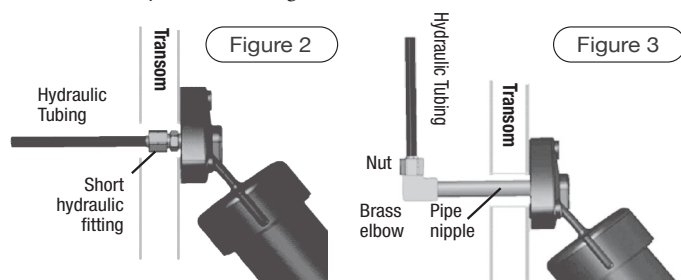

Step 2 - Outside the transom, unscrew and remove the actuator away from the transom. Remove the pipe nipple.

Step 3 - Snap the white plastic clip onto the shaft protruding from the bottom of the cylinder, and ensure the lower hinge is securely attached.

! This clip must be used to keep the spring inside the cylinder compressed. If there is no shaft protruding, the clip is not needed. Grasp the cylinder and upper hinge with both hands and unscrew counterclockwise from the cylinder body. A small amount of fluid may spill. Discard the old upper hinge.

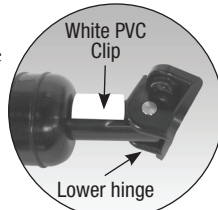

Step 4 - Insert the sensor rod into the piston (see Figure 4). Make sure that the O-ring is in place inside the new upper hinge. Insert the upper hinge spacer (see Figure 4) into the inside of the cylinder (Flanged edge facing up). Screw the new upper hinge onto the cylinder while keeping the sensor rod inserted into the center of the piston. Tighten the upper hinge as tight as you can by hand. You will finish tightening the cylinder in Step 7.

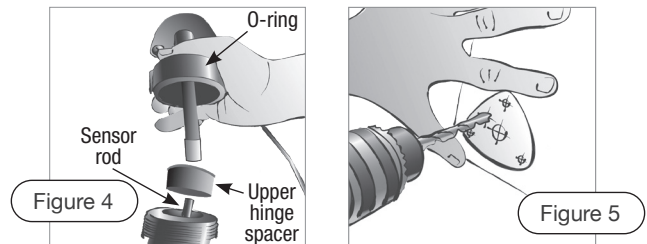

Step 5 - Remove the plastic clip from the piston and repeat steps 2 - 4 for the other cylinder.

Step 6 - Using the included template, drill a 5/16" hole into the transom for the sensor wire (see Figure 5 above). Screw the pipe nipple into the actuator upper hinge (NO Teflon tape or pipe dope). Tighten the nipple hand tight. Then, with vise grips, tighten two full turns ... NO MORE. Cover the end of the pipe nipple with masking tape. If you have the "Short through" transom fitting, using a 7/16" wrench, screw it in (NO Teflon tape or pipe dope) until the fitting is snug; the shoulder of the fitting will just touch the plastic of the upper hinge.

Step 7 - Carefully feed the sensor wire through the 5/16" hole. Apply sealant to the actuator upper hinge surface, around the pipe nipple, screw holes, and cable. Secure the actuator upper hinge to the transom with mounting screws. Grasp the cylinder body with both hands and tighten (clockwise) securely.

Step 8 - Inside the transom, remove the masking tape from the pipe nipples. Carefully wrap Teflon tape around the male threads of the pipe nipples. Holding the pipe nipples with vise grips (to prevent them from turning) re-secure the 90 degree elbows. Re-attach the hydraulic tubing, and tightening the nut finger tight. Snug the nut with a 1/2" wrench. Do not over-tighten. Note: If you have the "Short through" transom fittings, omit this step. Repeat for other side.

Step 9 - Run the gray sensor wires forward (where you run the sensor wires depends on the system you are installing onto. For example if you are installing to an AutoTrim Pro AP000A1HA you will run the sensors to the Control Unit, if you are installing to an Integrated Helm Control OBI9000H, you will run the wires directly to the Helm Display.)

Have questions? We're here to help.

Visit BennettTrimTabs.com or call (954)427-1400

! Please note that a sensor hole is only required for sensor-equipped upper hinges. If your upper hinge does not have sensor wires, do not drill the sensor hole.

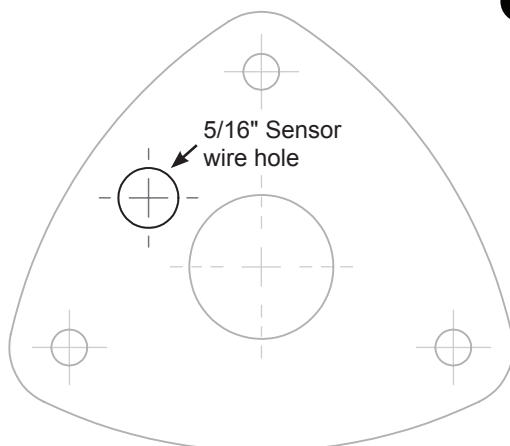

1"
Must be printed or copied at 100% scale

