

Before Installation

Before performing installation, read the entire instructions and make sure battery power is disconnected.

Required Tools and materials

- 7/16", 1/2" & 9/16" Wrench
- 5/16" Drill Bit
- Masking Tape
- Teflon Tape
- Electric Drill
- 3M 5200 Marine Grade Sealant
- Vise Grips

Installation Instructions

Installing New Upper Hinges with Sensors

Step 1 - Inside the transom, with the tabs in full up position, locate the trim tab hydraulic line. If there is no pipe nipple visible inside the transom, you have a "Short through" transom fitting connection, (Figure 2). Unscrew and remove the actuator away from the transom and use a 7/16" wrench to remove the tubing from the upper hinge. Skip to step 3 unless you have a standard installation.

For standard installations, detach the tubing from the brass elbow (some fluid will drip out). While holding the pipe nipple with vise grips, unscrew the brass elbow using a 9/16" wrench. Repeat this procedure for both the port and starboard cylinders (see Figure 3).

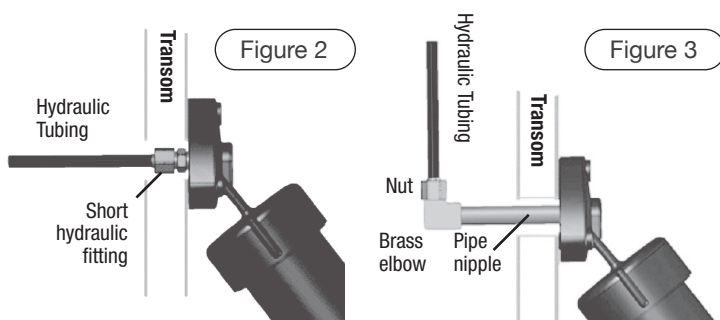

Step 2 - Outside the transom, unscrew and remove the actuator away from the transom. Remove the pipe nipple.

Step 3 - Snap the white plastic clip onto the shaft protruding from the bottom of the cylinder, and ensure the lower hinge is securely attached.

! This clip must be used to keep the spring inside the cylinder compressed. If there is no shaft protruding, the clip is not needed. Grasp the cylinder and upper hinge with both hands and unscrew counterclockwise from the cylinder body. A small amount of fluid may spill. Discard the old upper hinge.

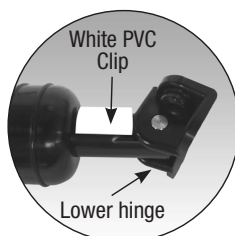

Step 4 - Insert the sensor rod into the piston (see Figure 4). Make sure that the O-ring is in place inside the new upper hinge. Insert the upper hinge spacer (see Figure 4) into the inside of the cylinder (Flanged edge facing up).

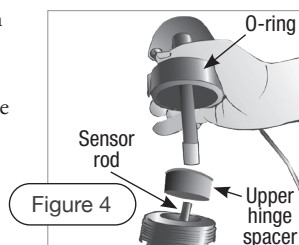

Screw the new upper hinge onto the cylinder while keeping the sensor rod inserted into center of the piston (Figure 4). Tighten the upper hinge as tight as you can by hand. You will finish tightening the cylinder in Step 7.

Step 5 - Remove the plastic clip from the piston and repeat steps 2 - 4 for the other cylinder.

Step 6 - Using the included template on the reverse side of this page, drill a 5/16" hole into the transom for the sensor wire (Figure 5). Screw the pipe nipple into the actuator upper hinge (NO Teflon tape or pipe dope). Tighten the nipple hand tight. Then, with vise grips, tighten two full turns ... NO MORE. Cover end of the pipe nipple with masking tape. If you have the short through-transom fitting, using a 7/16" wrench, screw it in (NO Teflon tape or pipe dope) until the fitting is snug; the shoulder of the fitting will just touch the plastic of the upper hinge.

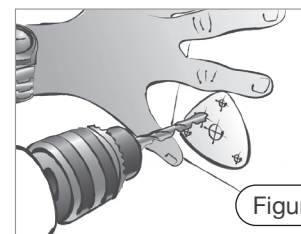

Figure 5

Step 7 - Carefully feed the sensor wire through the 5/16" hole. Apply sealant to the actuator upper hinge surface around the pipe nipple, screw holes, and cable. Secure the actuator upper hinge to the transom with mounting screws. Grasp the cylinder body with both hands and tighten (clockwise) securely.

Step 8 - Inside the transom, remove the masking tape from the pipe nipples. Carefully wrap Teflon tape around the male threads of the pipe nipples. Holding the pipe nipples with vise grips (to prevent them from turning) re-secure 90 degree elbows. Re-attach the hydraulic tubing, tightening the nut finger tight. Snug the nut with a 1/2" wrench. Do not over-tighten. Note: If you have the short through-transom fittings, omit this step. Repeat for the other side. Run the gray sensor wires to where you plan to mount the ATP Control Unit.

Step 9 - Connecting the AutoTrim Pro Display

Refer to the "Installation of System Components" section beginning on page 7 of the AutoTrim Pro Hydraulic Installation & User's Guide. Calibration instructions as well as troubleshooting information can also be found in the complete installation guide. **A digital version of this manual can be downloaded at BennettTrimTabs.com/Install.**

For information on installing a complete Bennett Hydraulic Actuator, please visit BennettTrimTabs.com/Install

Have Questions?

We're here to help

 Call us at (954)427-1400



See the reverse side for the system diagram and sensor wire hole drilling template

AutoTrimPro

SYSTEM DIAGRAM

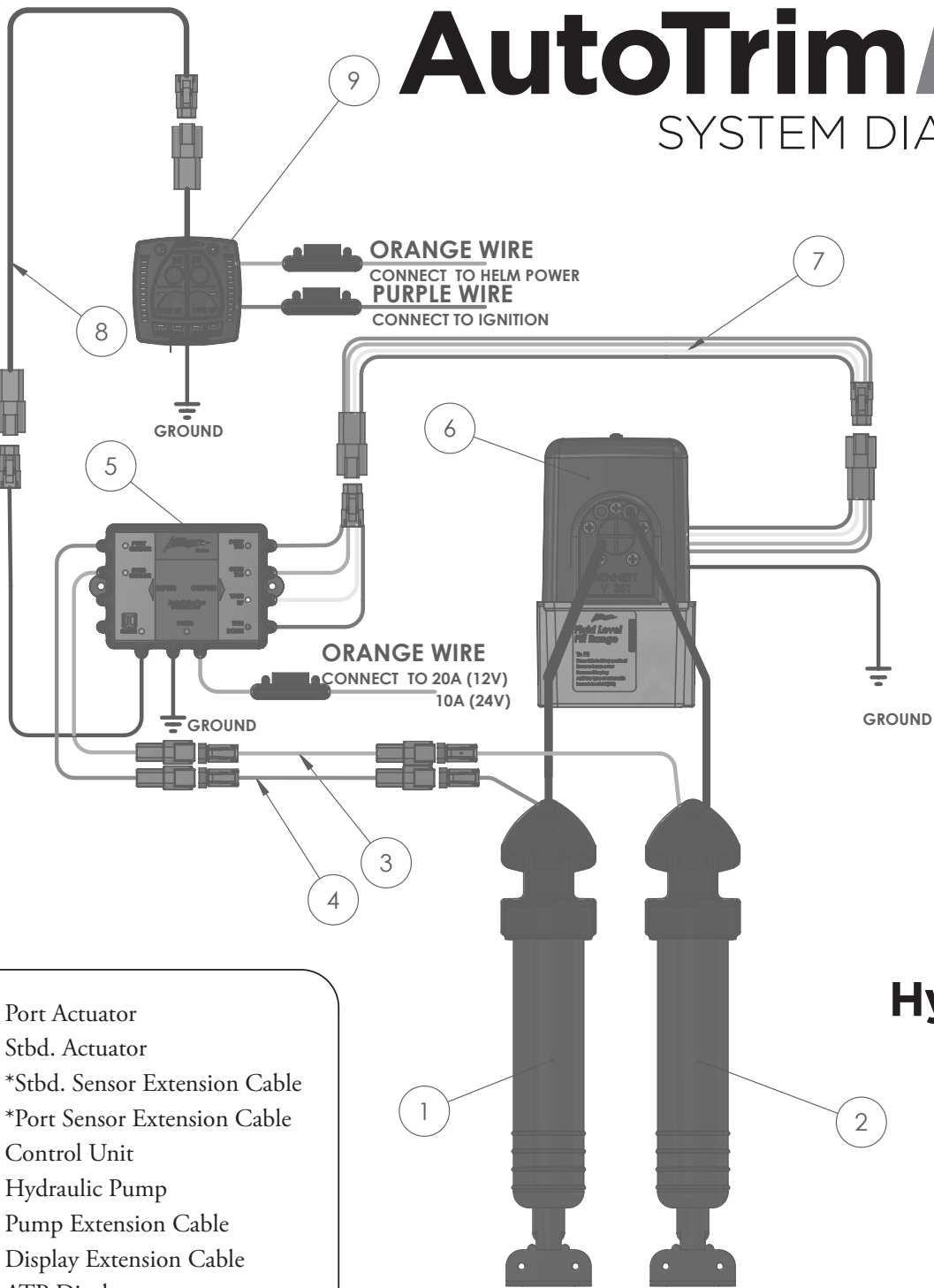

Classic Single Pump Hydraulic System

- 1. Port Actuator
 - 2. Stbd. Actuator
 - 3. *Stbd. Sensor Extension Cable
 - 4. *Port Sensor Extension Cable
 - 5. Control Unit
 - 6. Hydraulic Pump
 - 7. Pump Extension Cable
 - 8. Display Extension Cable
 - 9. ATP Display
- * Optional

Have Questions? **We're here to help.**

(954) 427-1400 BennettTrimTabs.com 550 Jim Moran Blvd., Deerfield Beach, FL 33442

BENNETT  MARINE

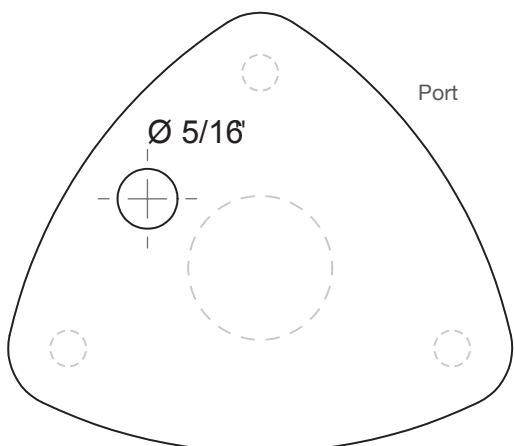

Templates must be printed or copied at 100% scale. Be sure to select "Actual Size" when printing from a PDF file.

